



MANUAL: ICE-CONTROL Anti-icing & Deicing Nozzles

INSTRUCTIONS FOR SAFE OPERATION AND MAINTENANCE

⚠️WARNING

Read instruction manual before use. Operation of this nozzle without understanding the manual and receiving proper training can be dangerous and is a misuse of this equipment. Call 1-800-348-2686 or 1-219-462-6161 with any questions.

This instruction manual is intended to familiarize ground support crew and maintenance personnel with the operation, servicing and safety procedures associated with TFT ice-control nozzles.

This manual should be kept available to all operating and maintenance personnel.

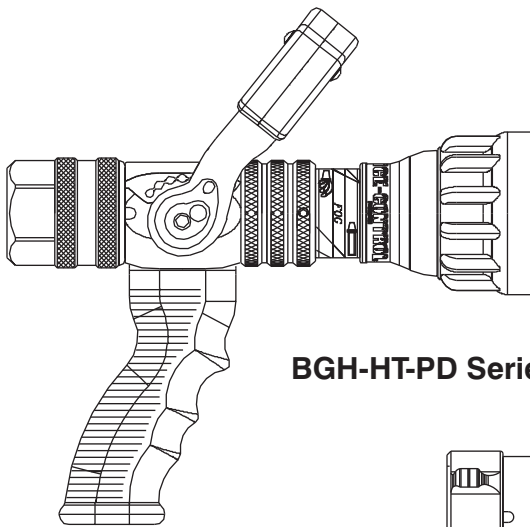

BGH-HT-PD Series

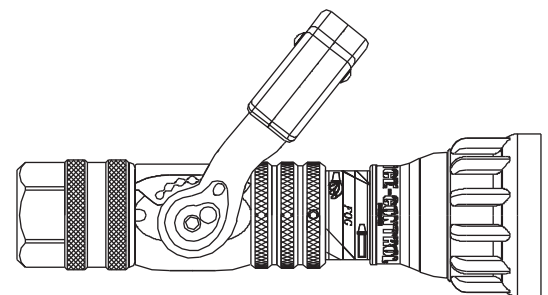

BH-HT-PD Series

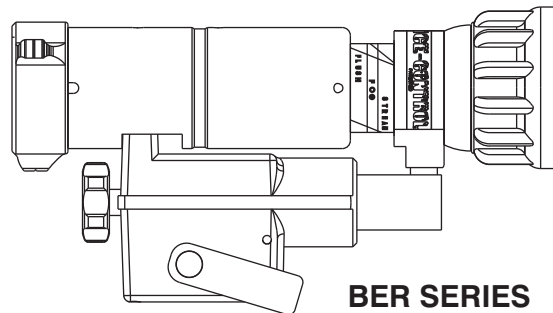

BER SERIES

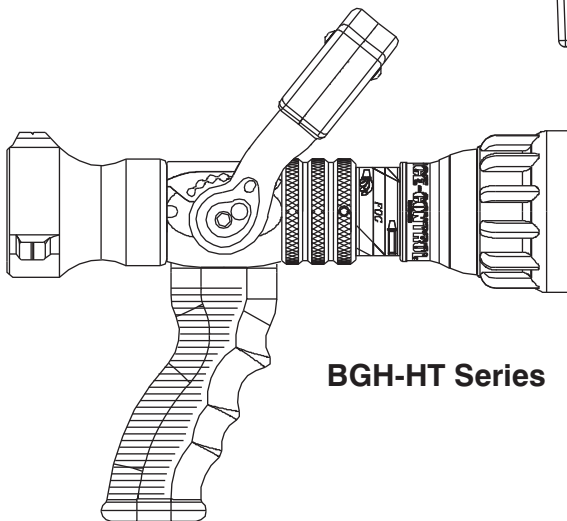

BGH-HT Series

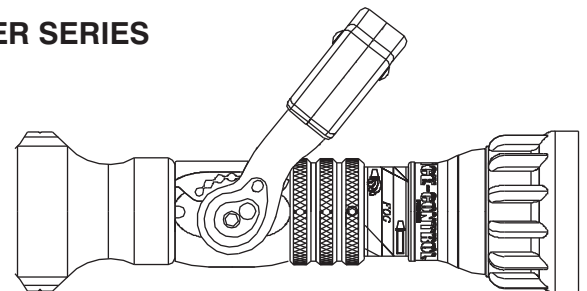

BH-HT Series

TASK FORCE TIPS, Inc.
Made in USA - <http://deicing.tft.com>

3701 Innovation Way • Valparaiso, IN 46383-9327 USA
800.348.2686 • 219.462.6161 • Fax 219.464.7155

TABLE OF CONTENTS

1.0 MEANING OF SAFETY SIGNAL WORDS	3
2.0 GENERAL INFORMATION	4
2.1 VARIOUS MODELS AND TERMS	4-5
3.0 FLOW CHARACTERISTICS	6
3.1 TRAJECTORY CHARTS	7
3.1.1 ANTI-ICING NOZZLES	7
3.1.2 DEICING NOZZLES	8
3.1.3 ELECTRIC REMOTE NOZZLES	9
4.0 NOZZLE CONTROLS	10
4.1 FLOW CONTROLS	10
4.1.1 LEVER TYPE FLOW CONTROL	10
4.1.2 ELECTRIC REMOTE NOZZLE.....	10
4.2 PATTERN AND FLUSH CONTROL	10
4.2.1 PATTERN CONTROL	10
4.2.1.1 MANUAL PATTERN CONTROL	10
4.2.1.2 ELECTRIC PATTERN CONTROL	10
4.2.2 FLUSH CONTROL.....	10
4.2.2.1 MANUAL CONTROL.....	10
4.2.2.2 ELECTRIC CONTROL.....	10
5.0 USE OF ICE-CONTROL NOZZLES	11
6.0 FIELD INSPECTION	12
7.0 PARTS LIST	13
7.1 ICE-CONTROL NOZZLE VALVED MODELS	13-14
7.2 ICE-CONTROL NOZZLE ELECTRIC MODEL.....	15-16
7.3 12-24V ACTUATOR ASSEMBLY W/PLUG.....	17
7.4 24-36V ACTUATOR ASSEMBLY	18
8.0 ANSWERS TO YOUR QUESTIONS	19
9.0 INSPECTION CHECKLIST	19
10.0 WARRANTY	BACK COVER

Note: These nozzles, while regularly used for ice control, have been modified to meet the needs of the individual aviation customers by their specifications and requirements. As modified firefighting nozzles, Task Force Tips relies on these specifications presented by the users, and does not independently test, confirm, or warrant, the suitability of any particular nozzle for an application. It is the responsibility of the end user to specify the flows, pressures, and configurations to meet their requirement and application.

1.0 MEANING OF SAFETY SIGNAL WORDS



This is a safety alert symbol. Throughout the text it alerts you to potential personal injury hazards. Obey all safety messages that follow to avoid possible injury or death.

A safety related message is identified by a safety alert symbol and a signal word to indicate the level of risk involved with a particular hazard. Per ANSI standard Z535.4-1998 the definition of the three signal words is as follows:

▲ DANGER

DANGER indicates an imminently hazardous situation which, if not avoided, will result in death or serious injury.

▲ WARNING

WARNING indicates a potentially hazardous situation which, if not avoided, could result in death or serious injury.

▲ CAUTION

CAUTION indicates a potentially hazardous situation which, if not avoided, may result in minor or moderate injury.

2.0 GENERAL INFORMATION

Task Force Tips ice-control nozzles have been specifically designed to apply water, glycol or water/glycol based ice-control fluids to aircraft exterior surfaces at fluid temperatures up to 210° F (99° C). The proper use of deicing agents aids ground support professionals in the removal of ice from aircraft fuselage, landing gear and wing surfaces. The proper use of anti-icing agents aids ground support professionals in their efforts to prevent ice and snow from adhering to the wings of aircraft. This may extend holdover times. These nozzles are only part of a complete ice-control system. Suitability of a particular nozzle for applying deicing or anti-icing fluids must be determined by the end user of the nozzle.

Valved ice-control nozzles have:

- *Automatic Pressure Control for optimum reach.*
- *Slide-Type valve with heat resistant EPDM seat - The valve design controls the flow through the nozzle while minimizing turbulence that causes shear and degradation of Anti-icing fluids.*
- *Pattern Control - This nozzle features a "toothless" bumper to reduce turbulence and can be easily adjusted for any desired spray pattern between a straight stream or wide spray position.*
- *Pistol Grip - (BGH models only) The pistol grip and flow control handle are insulated to protect the operator from the high temperatures generated by fluids passing through the nozzle. Color coded pistol grips and valve handle covers are available from Task Force Tips, Inc. in black (standard), green, red, blue, orange, yellow, pink, purple, tan, gray and white. All valved nozzles are shipped with black handle covers. All pistol grip style nozzles are shipped with black pistol grip and a return card which may be returned to request a free color coded pistol grip and valve handle of your choice.*

The Society of Automotive Engineers (SAE) G-12E subcommittee, Aircraft Ground Deicing Equipment, has accepted the following color-coding for deicing and anti-icing fluids.

Deicing Fluid — Red with Yellow Stripe

Anti-icing Fluid — Green with Yellow Stripe

Two pistol grips with the above coding are included with each BGH model nozzle if you wish to follow this practice.

- *One-Twist Flushing - Easily flushable while flowing to clear trapped debris.*
- *Warranty - TFT's five-year warranty and unsurpassed service with 24-hour factory turnaround time.*

Electric remote control ice-control nozzles have:

- Automatic Pressure Control for optimum reach.
- Pattern Control- Electrically operated pattern adjustment, features a "toothless" bumper to reduce turbulence, and can be easily adjusted for any desired spray pattern between a straight stream or wide spray position.
- Sealed electric motor with easy to use manual override.
- Flush - Easily flushable while flowing to clear trapped debris.
- Swivel connecting coupling for ease of installation.
- Warranty - TFT's five-year warranty and unsurpassed service with 24-hour factory turnaround time.

2.1 VARIOUS MODELS AND TERMS

ANTI-ICING NOZZLES - FOR USE WITH ANTI-ICING FLUIDS

MODEL	FLOW RANGE (4)	NOMINAL (5) PRESSURE	STANDARD COUPLING	VALVED	PATTERN CONTROL	FIGURE
BER-HT75	10-60 gpm*** 38-227 lpm***	75 psi 5 bar	1.5"-9 NH	NO	ELECTRIC (12-24VDC)	1
BER-HT75-HV	10-60 gpm*** 38-227 lpm***	75 psi 5 bar	1.5"-9 NH	NO	ELECTRIC (24-36VDC)	1
BGH-HT75-PD	10-60 gpm*** 38-227 lpm***	75 psi 5 bar	1.0"-11.5 NPT	YES	MANUAL TWIST	2
BH-HT75	10-60 gpm*** 38-227 lpm***	75 psi 5 bar	1.5"-9 NH	YES	MANUAL TWIST	5
BGH-HT50	10-60 gpm*** 38-227 lpm***	50 psi 3 bar	1.5"-9 NH	YES	MANUAL TWIST	4
BH-HT50	10-60 gpm*** 38-227 lpm***	50psi 3 bar	1.5"-9 NH	YES	MANUAL TWIST	5
BH-HT50-IF	10-60 gpm*** 38-227 lpm***	50psi 3 bar	1.5"-11 NPSH	YES	MANUAL TWIST	5
BGH-HT50-DS	10-60 gpm*** 38-227 lpm***	50 psi 3 bar	1.312"-12 SAE	YES	MANUAL TWIST	4
BGH-HT50-PD	10-60 gpm*** 38-227 lpm***	50 psi 3 bar	1.0"-11.5 NPT	YES	MANUAL TWIST	2
BH-HT50	10-60 gpm*** 38-227 lpm***	50 psi 3 bar	1.5"- 9 NH	YES	MANUAL TWIST	5

DE-ICING NOZZLES - FOR USE WITH DE-ICING FLUIDS

MODEL	FLOW RANGE (4)	NOMINAL (5) PRESSURE	STANDARD COUPLING	VALVED	PATTERN CONTROL	FIGURE
BER-HT150	10-60 gpm 38-227 lpm	150 psi 10 bar	1.5"-9 NH	NO	ELECTRIC (12-24VDC)	1
BERP-HT150*	10-60 gpm 38-227 lpm	150 psi 10 bar	1.5"-9 NH	NO	ELECTRIC (12-24VDC) 6 PIN CABLE CONNECTION	1
BER-HT150-HV	10-60 gpm 38-227 lpm	150 psi 10 bar	1.5"-9 NH	NO	ELECTRIC (24-36VDC)	1
BGH-HT100-PD	10-60 gpm 38-227 lpm	100 psi 7 bar	1.0"-11.5 NPT	YES	MANUAL TWIST	2
BH-HT100-PD	10-60 gpm 38-227 lpm	100 psi 7 bar	1.0"-11.5 NPT	YES	MANUAL TWIST	3
BH-HT100-IF	10-60 gpm 38-227 lpm	100 psi 7 bar	1.5"-11 NPSH	YES	MANUAL TWIST	5
BGH-HT150-PD	10-60 gpm 38-227 lpm	150 psi 10 bar	1.0"-11.5 NPT	YES	MANUAL TWIST	2
BH-HT150-PD	10-60 gpm 38-227 lpm	150 psi 10 bar	1.0"-11.5 NPT	YES	MANUAL TWIST	3
BGH-HT1503PD	20-25 gpm 76-95 lpm	150 psi 10 bar	1.0"-11.5 NPT	YES	MANUAL TWIST	2

*** CAN BE USED FOR ANTI-ICING FLUIDS WHEN OPERATED BETWEEN 20-30 GPM

(4) CONVERSION - 1 GPM = 3.785 LITERS, (5) CONVERSION - 1 PSI = 0.067 BAR

COMBINATION NOZZLES - WITH LOW FLOW FIXED GALLONAGE SETTING FOR ANTI-ICING WITH ANTI-ICING FLUIDS AND HIGH FLOW AUTOMATIC PRESSURE CONTROL SETTING FOR DEICING WITH DEICING FLUIDS

COMBINATION NOZZLES

MODEL	ANTI-ICING SETTING (4,5)	DEICING SETTING (4,5)	STANDARD COUPLING	VALVED	PATTERN CONTROL	FIGURE
BER-HT120	20 gpm @ 50psi 76 lpm @ 3 bar	80 gpm @120 psi 303 lpm @ 8 bar	1.5"-9 NH	NO	ELECTRIC (12-24VDC)	1
BER-HT120-HV	20 gpm @ 50psi 76 lpm @ 3 bar	80 gpm @120 psi 303 lpm @ 8 bar	1.5"-9 NH	NO	ELECTRIC (24-36VDC)	1
BER-HT1501	20 gpm @ 50psi 76 lpm @ 3 bar	80 gpm @150 psi 303 lpm @ 10 bar	1.5"-9 NH	NO	ELECTRIC (12-24VDC)	1
BER-HT1502	20 gpm @ 50psi 76 lpm @ 3 bar	40 gpm @ 150 psi 151 lpm @ 10 bar	1.5"-9 NH	NO	ELECTRIC (12-24 VDC)	1
BER-HT1501HV	20 gpm @ 50psi 76 lpm @ 3 bar	80 gpm @150 psi 303 lpm @ 10 bar	1.5"-9 NH	NO	ELECTRIC (24-36VDC)	1
BGH-HT120-PD	20 gpm @ 50psi 76 lpm @ 3 bar	80 gpm @120 psi 303 lpm @ 8 bar	1.0"-11.5 NPT	YES	MANUAL TWIST	2
BGH-HT1502PD	20 gpm @ 50psi 76 lpm @ 3 bar	40 gpm @ 150 psi 151 lpm @ 10 bar	1.0"-11.5 NPT	YES	MANUAL TWIST	2
BH-HT120-IF	20 gpm @ 50psi 76 lpm @ 3 bar	80 gpm @120 psi 303 lpm @ 8 bar	1.0"-11 NPSH	YES	MANUAL TWIST	3
BH-HT120-PD	20 gpm @ 50psi 76 lpm @ 3 bar	80 gpm @120 psi 303 lpm @ 8 bar	1.0"-11.5 NPT	YES	MANUAL TWIST	3

*** CAN BE USED FOR ANTI-ICING FLUIDS WHEN OPERATED BETWEEN 20-30 GPM

(4) CONVERSION - 1 GPM = 3.785 LITERS, (5) CONVERSION - 1 PSI = 0.067 BAR



Mismatched or damaged threads may cause nozzle to leak heated fluid or uncouple from hose/piping under pressure and could cause injury. Nozzle must be mated to hose/piping with matched threads.

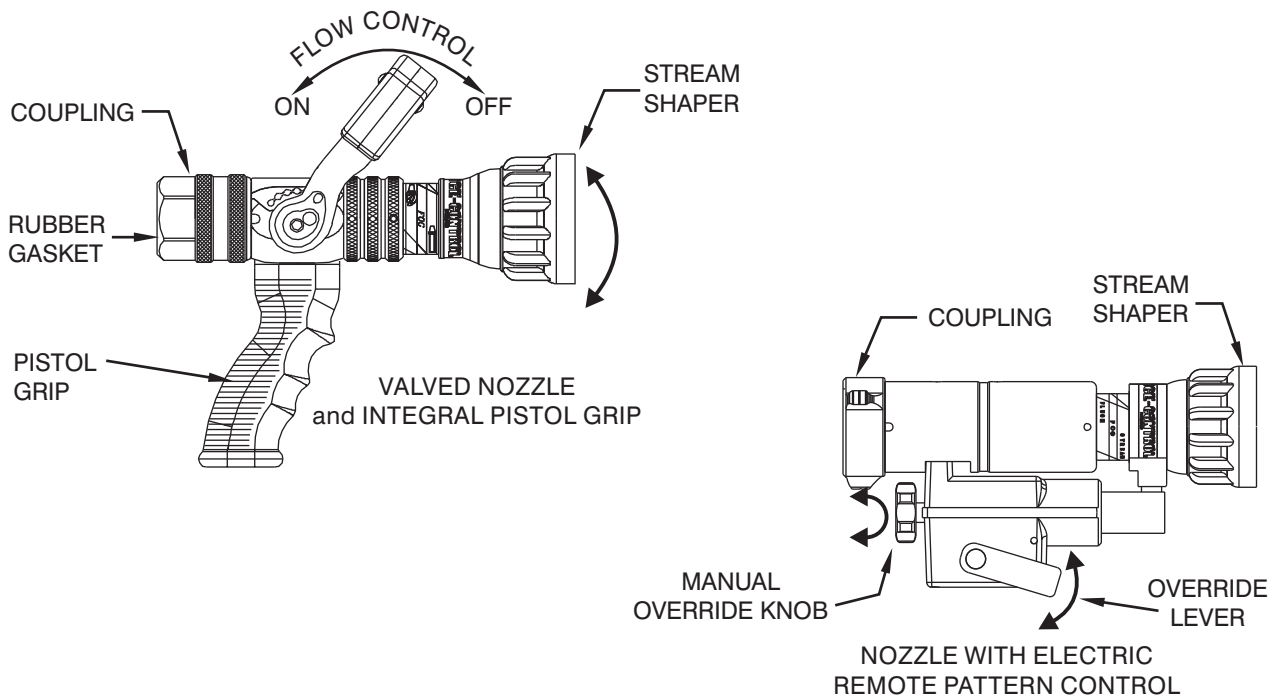

FIGURE 1 - COMMON MODELS AND TERMS

3.0 FLOW CHARACTERISTICS

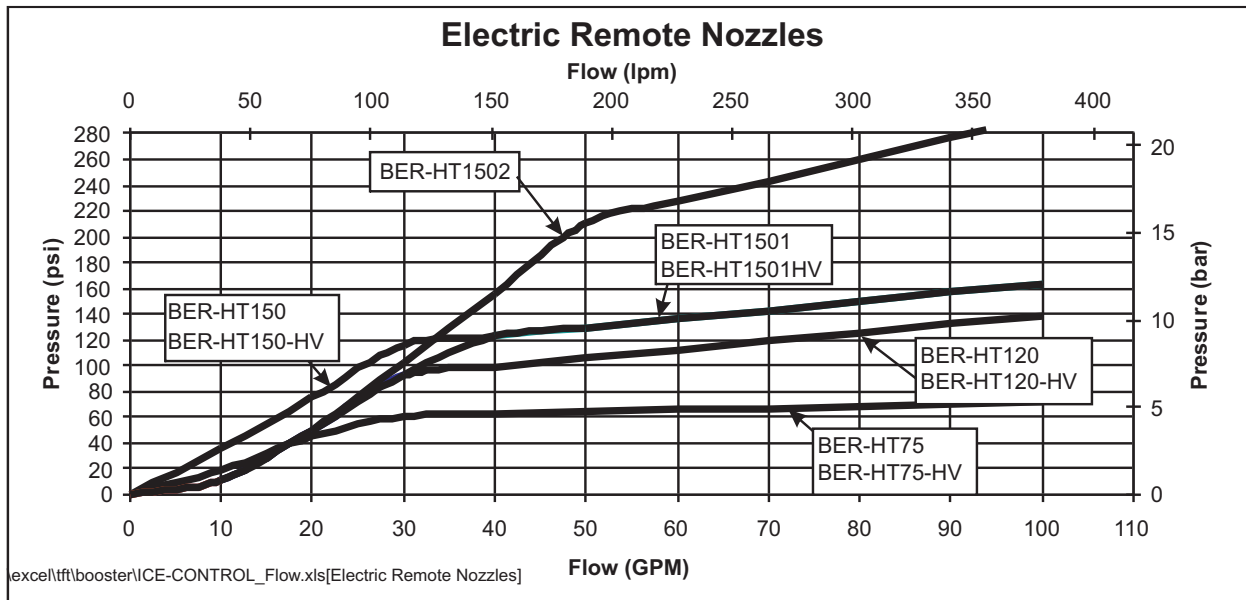
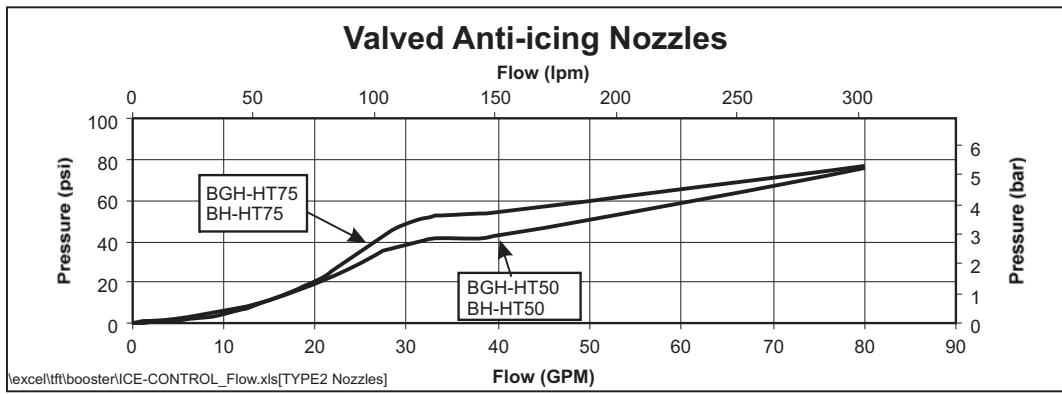
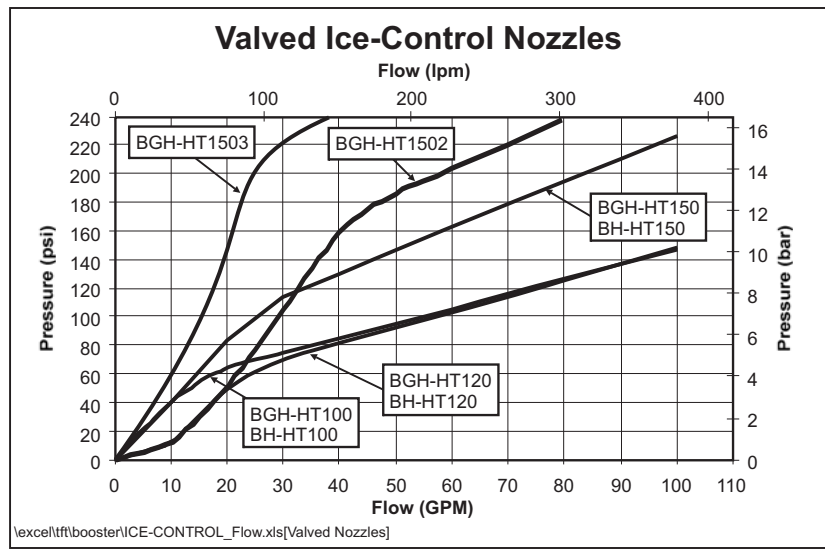

FIGURE 2 - FLOW CURVES

Friction pressure losses may vary due to differences in hoses/piping construction resulting in flows different than those shown. Flows can be calculated using conventional hydraulics.

These flow curves are for reference only. User must determine suitability of the stream for the particular purpose for which it is being used. Such factors as fluid/water ratio, manufacturer of fluid, fluid temperature and equipment used to supply fluid to the nozzle may produce variation from the flows and pressures shown above.

3.1 TRAJECTORY CHARTS FOR ICE-CONTROL NOZZLES

3.1.1 ANTI-ICING NOZZLES

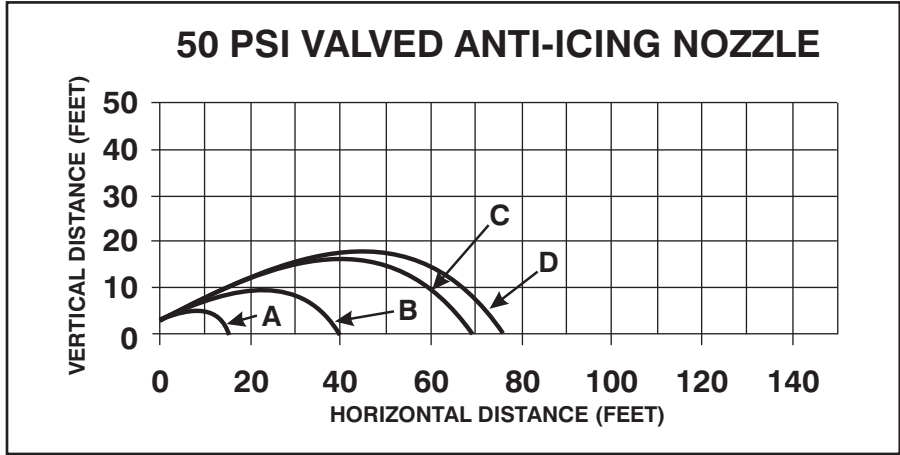

CURVE	GPM FLOW	PSI INLET PRESSURE	LBS REACTION
A	10	19	1
B	20	45	4
C	30	60	9
D	40	64	13

CURVE	LPM FLOW	KGf/CM ² INLET PRESSURE	KGf REACTION
A	38	1.3	.5
B	76	3.1	2.1
C	110	4.1	4.5
D	150	4.4	6.3

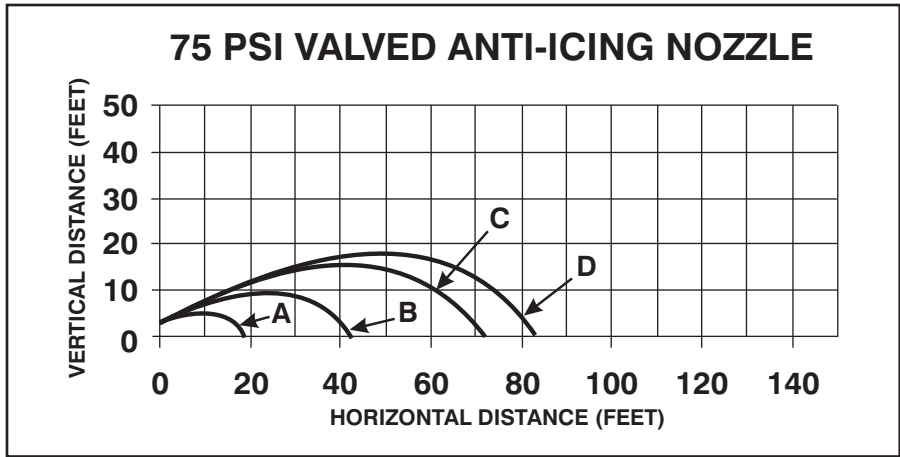

CURVE	GPM FLOW	PSI INLET PRESSURE	LBS REACTION
A	10	5	1
B	20	21	5
C	30	49	11
D	40	55	15

CURVE	LPM FLOW	KGf/CM ² INLET PRESSURE	KGf REACTION
A	38	.3	.5
B	76	1.4	2.2
C	110	3.4	5.0
D	150	3.8	7.1

These trajectories, reach and reaction numbers are provided for reference. All data based on 30 degree nozzle discharge angle, in straight stream setting. Actual trajectories, reach and reactions may vary with wind conditions, fluid type, fluid/water ratio, fluid temperature, pressure and flow at the nozzle. It is the operator's responsibility to determine that the system provides adequate reach for the intended purpose.



Deicing nozzles operate at high pressures. Direct impingement of the stream at right angles to some aircraft surfaces may cause deformation or damage. User should direct stream at shallow angles to sensitive surfaces.

3.1.2 DEICING NOZZLES

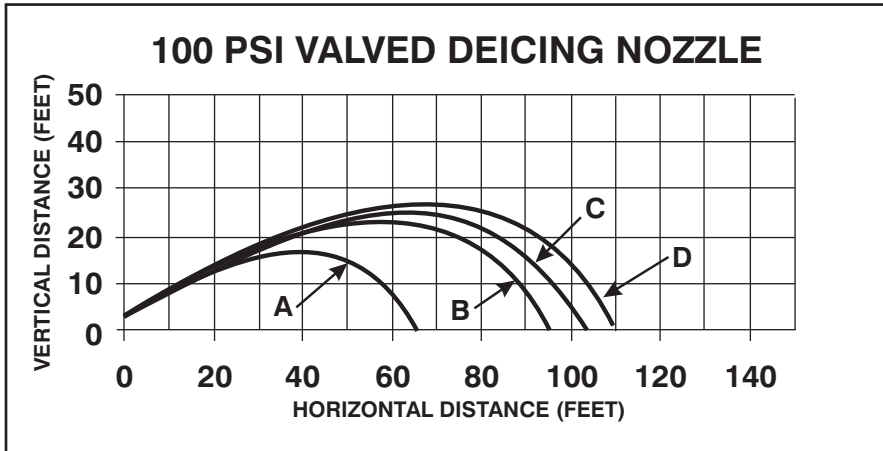

CURVE	GPM FLOW	PSI INLET PRESSURE	LBS REACTION
A	20	64	8
B	40	85	19
C	50	95	25
D	60	100	31

CURVE	LPM FLOW	KG/CM ² INLET PRESSURE	KG F REACTION
A	76	4.4	3.8
B	150	5.9	8.8
C	190	6.6	12
D	230	6.9	15

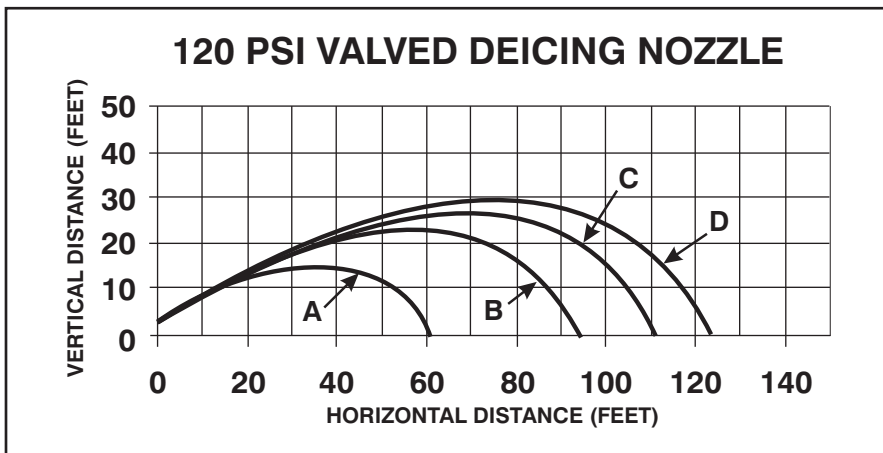

CURVE	GPM FLOW	PSI INLET PRESSURE	LBS REACTION
A	20	50	7
B	40	81	18
C	60	105	31
D	80	120	44

CURVE	LPM FLOW	KG/CM ² INLET PRESSURE	KG F REACTION
A	76	3.4	3.4
B	150	5.6	8.6
C	230	7.2	15
D	300	8.3	21

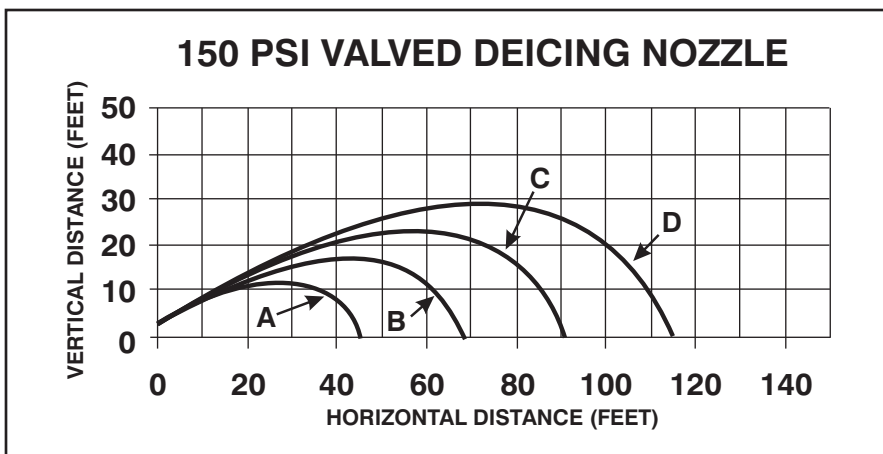

CURVE	GPM FLOW	PSI INLET PRESSURE	LBS REACTION
A	10	40	3
B	20	83	9
C	30	114	16
D	50	150	31

CURVE	LPM FLOW	KG/CM ² INLET PRESSURE	KG F REACTION
A	38	2.8	1.5
B	76	5.7	4.3
C	110	7.9	7.6
D	190	10	15

These trajectories, reach and reaction numbers are provided for reference. All data based on 30 degree nozzle discharge angle, in straight stream setting. Actual trajectories, reach and reactions may vary with wind conditions, fluid type, fluid/water ratio, fluid temperature, pressure and flow at the nozzle. It is the operator's responsibility to determine that the system provides adequate reach for the intended purpose.



Deicing nozzles operate at high pressures. Direct impingement of the stream at right angles to some aircraft surfaces may cause deformation or damage. User should direct stream at shallow angles to sensitive surfaces.

3.1.3 ELECTRIC REMOTE NOZZLES

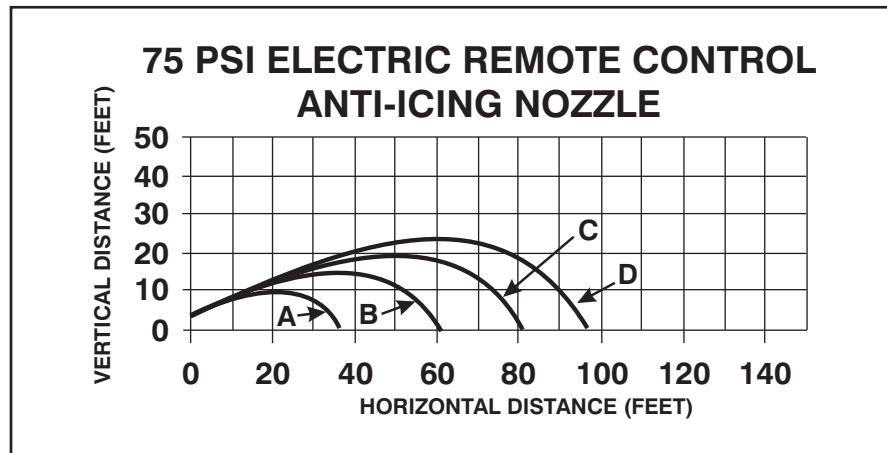

CURVE	GPM FLOW	PSI INLET PRESSURE	LBS REACTION
A	10	19	2
B	20	45	7
C	30	60	12
D	50	64	20

CURVE	LPM FLOW	KGf/CM ² INLET PRESSURE	KGf REACTION
A	38	1.3	1.0
B	76	3.1	3.2
C	110	4.1	5.5
D	190	4.4	9.5

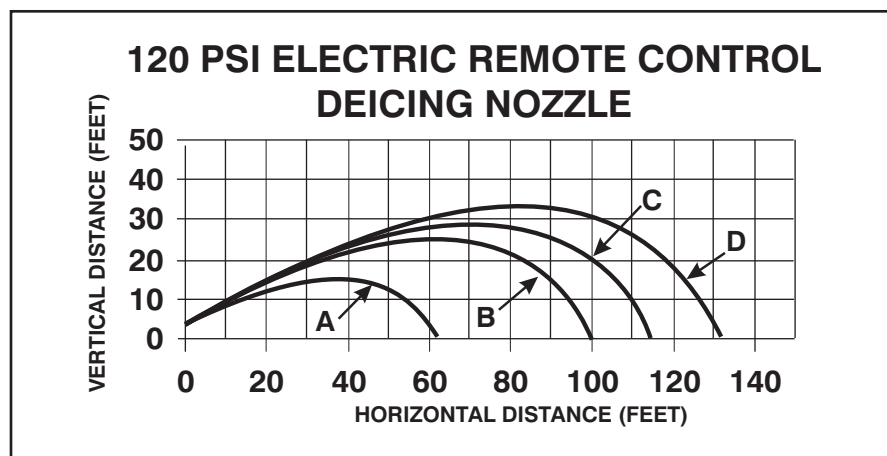

CURVE	GPM FLOW	PSI INLET PRESSURE	LBS REACTION
A	20	50	7
B	40	93	19
C	60	106	31
D	80	120	44

CURVE	LPM FLOW	KGf/CM ² INLET PRESSURE	KGf REACTION
A	76	3.4	3.4
B	150	6.4	9.2
C	230	7.3	15
D	300	8.3	21

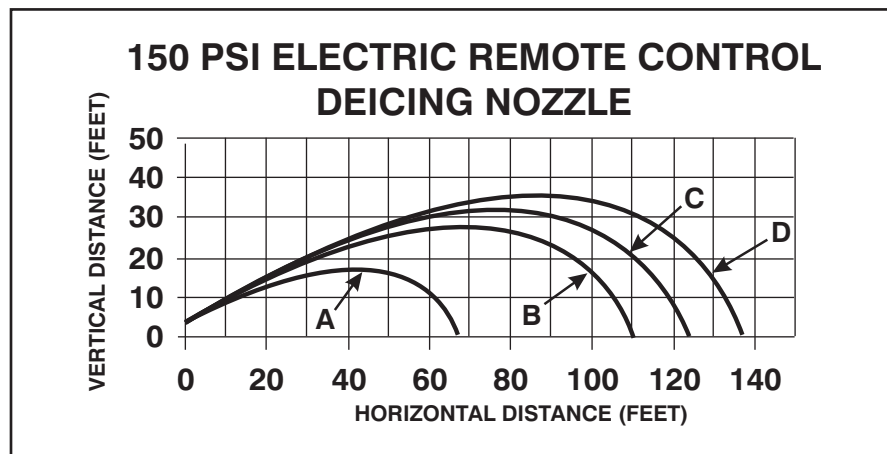

CURVE	GPM FLOW	PSI INLET PRESSURE	LBS REACTION
A	20	74	9
B	40	123	22
C	60	136	35
D	80	150	49

CURVE	LPM FLOW	KGf/CM ² INLET PRESSURE	KGf REACTION
A	76	5.1	4.1
B	150	8.5	11
C	230	9.4	17
D	300	10	23

These trajectories, reach and reaction numbers are provided for reference. All data based on 30 degree nozzle discharge angle, in straight stream setting. Actual trajectories, reach and reactions may vary with wind conditions, fluid type, fluid/water ratio, fluid temperature, pressure and flow at the nozzle. It is the operator's responsibility to determine that the system provides adequate reach for the intended purpose.



Deicing nozzles operate at high pressures. Direct impingement of the stream at right angles to some aircraft surfaces may cause deformation or damage. User should direct stream at shallow angles to sensitive surfaces.

4.0 NOZZLE CONTROLS

4.1 FLOW CONTROL

4.1.1 LEVER TYPE FLOW CONTROL

On models that use a bail-type valve handle, the nozzle is shut off when the handle is fully forward. The valve handle has six detent flow positions. These detent positions allow the nozzle operator to regulate the fluid flow of the nozzle depending on the need or what can be safely and effectively handled.

4.1.2 ELECTRIC REMOTE NOZZLES

On models with electric remote control of the shaper there is no built-in flow control. Flow control must be provided for elsewhere in the system.

4.2 PATTERN AND FLUSH CONTROL

4.2.1 PATTERN CONTROL

4.2.1.1 MANUAL PATTERN CONTROL

On models that use a twist-type pattern control, a continuously variable pattern from narrow to wide is available. Turning the SHAPER clockwise, as seen from the operating position behind the nozzle, moves the SHAPER to the straight stream position. Turning the SHAPER counterclockwise will result in an increasingly wider pattern. An indicator band on the nozzle barrel shows which position the SHAPER is in by progressively uncovering symbols for FLUSHING, WIDE SPRAY and STRAIGHT STREAM.

4.2.1.2 ELECTRIC PATTERN CONTROL

On models that use an electric pattern control, a continuously variable pattern from narrow to wide is available by operating the electric actuator according to the directions supplied with the actuator control panel. Extending the SHAPER outwards, as seen from behind the nozzle, moves the SHAPER to the straight stream position. Retracting the SHAPER inwards will result in an increasingly wider pattern. The actuator "free wheels" at each end of its stroke making limit switches unnecessary. A manual override lever on the electric actuator, when depressed, allows the manual override knob to be turned. Turning the knob counterclockwise, as seen from the operating position behind the nozzle, extends the SHAPER towards the straight stream position. Turning the knob clockwise retracts the SHAPER towards the wide spray position.



Electric remote nozzle has finger pinch points. Keep fingers away from nozzle when using electric control.

4.2.2 FLUSH CONTROL

Debris may get caught inside the nozzle. This trapped material will cause poor stream quality, shortened reach and reduced flow. To remove this trapped debris, the nozzle can be flushed as follows:

4.2.2.1 VALVED NOZZLE FLUSHING

While still flowing fluid, turn the SHAPER counterclockwise past the wide spray position (increased resistance to turning will be felt on the SHAPER as the nozzle goes into flush.) This will open the nozzle allowing debris to pass through. Rotate the SHAPER clockwise and out of flush to continue normal operation. During flush, the nozzle will lose much of its reaction force and reach as the pressure drops. The nozzle operator must be prepared for an increase in reaction, reach and pressure when returning the nozzle from the flush position to normal operation to retain control of the nozzle and stream. Operating the nozzle in the flush position will flow increased volumes of fluid. Operate in the flush position only when necessary and only for a short amount of time to prevent fluid waste.



Heated ice-control fluids are capable of causing burns. Direct stream away from personnel when flushing as hot fluid may splash to the ground directly under the nozzle.

4.2.2.2 ELECTRIC REMOTE FLUSHING

While still flowing fluid, retract the SHAPER backwards past the wide spray position (as viewed from behind the nozzle) until it reaches its stop. This will open the nozzle allowing debris to pass through. When the debris has been flushed out, extend the SHAPER outwards until it is out of flush as determined by the markings on the barrel and the force of the stream to continue normal operation. Flushing may also be accomplished in the manual override mode of operation by moving past the wide spray position. See 4.2.1.2 for instruction on how to use manual override. During flush, the nozzle will lose much of its reaction force and reach as the pressure drops. Operating the nozzle in the flush position will flow increased volumes of fluid. Operate in the flush position only when necessary to prevent fluid waste.



Debris in nozzle can result in ineffective stream. Flush or uncouple nozzle to remove debris. Remove all pressure and flow from the nozzle before uncoupling.



Heated ice-control fluids are capable of causing burns. Direct stream away from personnel when flushing as hot fluid may splash to the ground directly under the nozzle.

5.0 OPERATION OF ICE-CONTROL NOZZLES

IT IS THE RESPONSIBILITY OF THE GROUND CREW MANAGEMENT TO DETERMINE PHYSICAL CAPABILITIES AND SUITABILITY FOR AN INDIVIDUAL'S USE OF THIS EQUIPMENT.

The methods used in applying ice-control fluids to aircraft are the responsibility of the agency performing the ice-control fluid application. Many factors contribute to the proper control of ice on an aircraft. The nozzle is only one part of a complete ice control system. Flow, pressure at the nozzle, fluid temperature, type of fluid, method of application, outside air temperature, precipitation, aircraft surface temperature and other factors must be taken into account when dealing with ice conditions. The proper methods must be determined by each agency for their particular conditions.

Where a nozzle is listed as Anti-icing capable, flow and pressure must be controlled within the rating of the nozzle to minimize shearing degradation of the fluid.



Discharge of anti-icing fluids from nozzles at flows higher than 50 GPM or 85 psi may result in degradation of the fluid and render it ineffective in preventing a buildup of ice on aircraft surfaces prior to takeoff. Consult fluid manufacturer's recommended guidelines.

Rated fluid temperatures at the nozzle must not be exceeded. Use of saltwater in these nozzles is not permissible and will lead to a shortened service life. Some features of this nozzle that the operator should be aware of are:

- **Automatic Pressure Control for deicing** - When used for deicing, these nozzles from Task Force Tips incorporate a pressure regulating mechanism, which means the fluid discharge velocity is nearly constant. With a constant nozzle discharge pressure, the deicing agent will have optimum reach at all flow settings, thereby reducing waste due to insufficient range of the stream.
- **Slide-Type valve with heat resistant EPDM seat** - On nozzles with a valve, the valve design controls the flow through the nozzle while minimizing turbulence that causes shear and degradation of anti-icing fluids. Because of this feature, the nozzle can be operated at any valve handle position, thereby allowing the operator to regulate the amount of agent being applied. This gives the operator the ability to conserve fluid and minimize waste without sacrificing reach or range of the stream. Unlike a ball valve, the stainless steel slide valve is not directly in the flow path and will not tighten under pressure, or bind with age. Therefore, it remains easy to operate.
- **Pattern Control** - This nozzle features a "toothless" bumper to reduce turbulence and can be easily adjusted for any desired spray pattern by moving the shaper between a straight stream or wide spray position. This will be beneficial when applying fluids to sensitive areas of the aircraft.
- **Sealed electric motor with easy-to-use manual override** - On electric remote models, the nozzle is equipped with a sealed motor/gear housing which prevents contamination of the actuator with dirt and fluids. The actuator features an easy-to-use override mechanism to allow manual setting of the pattern or to place the nozzle into flush mode.
- **Flushable while flowing** - The nozzle shaper, when retracted fully, puts the nozzle into flush, providing an oversized fluid passageway which allows trapped debris to exit the nozzle. On manual models, an increase in turning force on the shaper signals the operator that the nozzle is moving into flush.



An inadequate supply of nozzle pressure and/or flow will cause an ineffective stream and can result in incomplete removal or incomplete protection from the build-up of ice on flight surfaces which may lead to injury, death or loss of property. Call 800-348-2686 for assistance.



Ice-control fluid streams are capable of injury and damage. Heated streams can cling to and burn unprotected flesh and eyes. Do not direct fluid stream or allow splash to cause injury to persons or property.



Failure to restrain nozzle reaction can cause injury from loss of footing and/or whipping. With handheld nozzles, the nozzle operator must always be positioned to restrain the nozzle reaction in the event of those changes. In case of whipping, retreat from the nozzle immediately. Do not attempt to regain control of nozzle while flowing fluid.



Breathing ice-control fluid fumes can be hazardous to your health. Avoid working downwind. Avoid splash back. Consult fluid manufacturer's safety guidelines.

6.0 FIELD INSPECTION

Task Force Tip's Ice-Control Nozzles are designed and manufactured to be damage resistant and require minimal maintenance. However, as the primary fluid application tool upon which aircraft ice-control depends, they should be treated accordingly.



Nozzle must be periodically inspected for proper operation and function according to Inspection Checklist in section 10.0. Any nozzle that fails inspection is dangerous to use and must be repaired before using.

Performance tests shall be conducted on Ice-Control nozzles after repair, or anytime a problem is reported to verify operation in accordance with TFT test procedures. Consult factory for the procedure that corresponds to the model and serial number of the nozzle. Any equipment which fails the related test criteria should be removed from service immediately. Equipment can be returned to the factory for service and testing.

Factory service is available with repair time seldom exceeding one day in our facility. Factory serviced nozzles are repaired by experienced technicians to original specifications, fully tested and promptly returned. Any returns should include a note as to the nature of the problem, who to reach in case of questions and if a repair estimate is required. A service request form is available on our website, www.tft.com.

Repair parts are available for those wishing to perform their own repairs. Task Force Tips assumes no liability for damage to equipment or injury to personnel that is a result of user service.



Any alterations to the nozzle and its markings could diminish safety and constitutes a misuse of this product. Do not alter the nozzle or its markings.

All Task Force Tip nozzles are factory lubricated with high quality silicone grease. This lubricant has excellent washout resistance and long term performance. If your operation has unusually hard or sandy water, the moving parts may be affected. Foam agents and water additives contain soaps and chemicals that may break down the factory lubrication.

The moving parts of the nozzle should be checked on a regular basis for smooth and free operation, and signs of damage. **IF THE NOZZLE IS OPERATING CORRECTLY, THEN NO ADDITIONAL LUBRICATION IS NEEDED.** Any nozzle that is not operating correctly should be immediately removed from service and the problem corrected.

For recommended lubrication, view service manual (LIB-020) for your specific model.

7.0 PARTS LIST

7.1 ICE-CONTROL NOZZLE VALVED MODELS

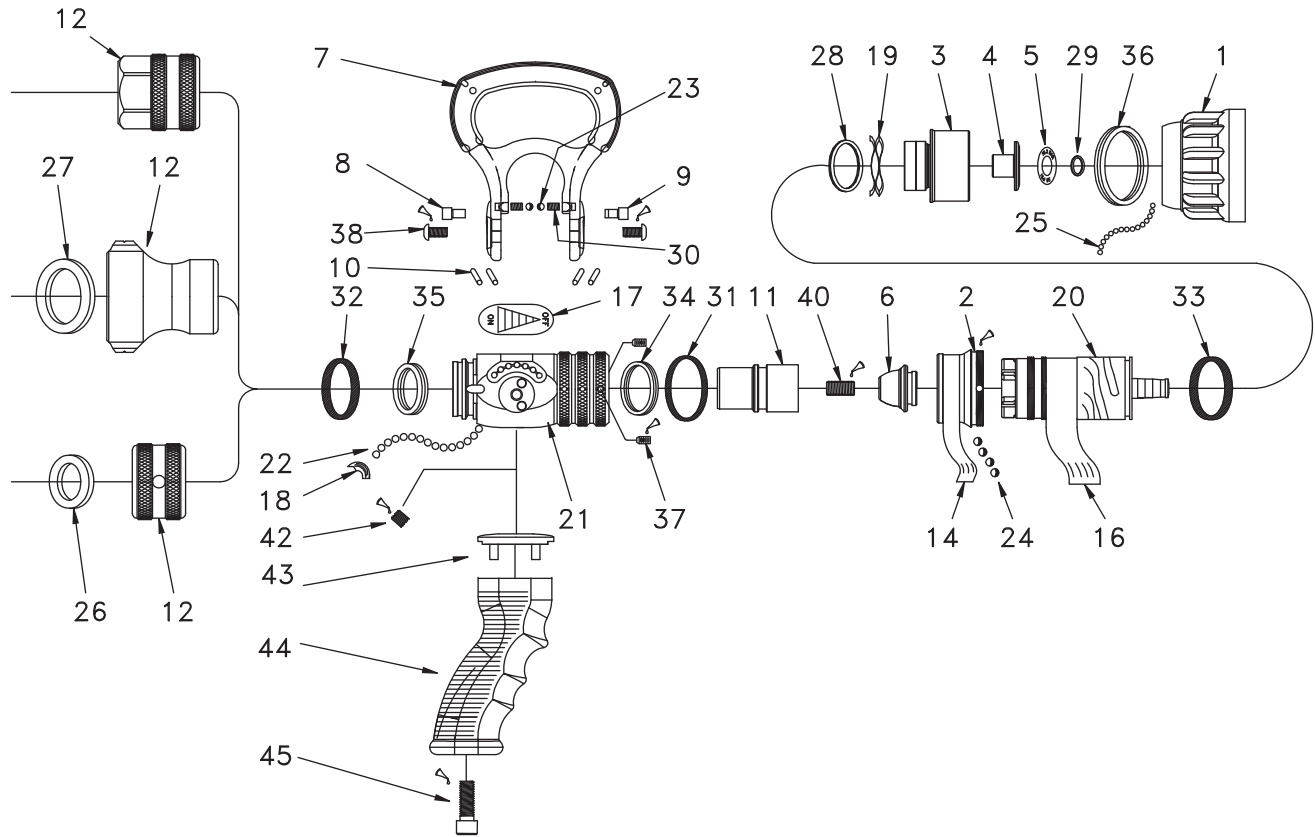

REF #	QTY	MODEL NUMBER		DESCRIPTION
		(a) BGH-HT50 (b) BH-HT50 (c) BGH-HT50-DS (d) BGH-HT50-PD (e) BGH-HT75-PD (k) BH-HT50 (n) BH-HT75	(f) BGH-HT100-PD (g) BH-HT100-PD (h) BGH-HT120-PD (i) BGH-HT150-PD (j) BH-HT150-PD (l) BH-HT120-PD (m) BH-HT120	
1	1	B504	B504	BUMPER NO TEETH
2	1	B510	B510	SHAPER GUIDE
3	1	B524	B524	BARREL CONE
4	1	B560	B560	BAFFLE
5	1	B568 (a,b,c,d,k)	—	50 PSI SPRING WASHER
	1	B567 (e,n)	—	75 PSI SPRING WASHER
	1	—	B565 (f,g)	100 PSI SPRING WASHER
	1	—	B563 (h,l,m)	120 PSI SPRING WASHER
	1	—	B566 (i,j)	150 PSI SPRING WASHER
	1	—	B561 (o)	150 PSI SPRING WASHER
	1	—	B559(p)	150 PSI SPRING WASHER
6	1	B594	B594	HIGH-TEMP NOSE CONE
7	1	B622	B622	WIDE HANDLE
	4	VT08E32BH375	VT08E32BH375	#8-32X3/8 BUTTON HEAD SCREW
	2	HM625-BLK	HM625-BLK	HANDLE COVER
8	1	B630	B630	CAM SCREW
9	1	B635	B635	SAFETY SCREW
10	4	B650	B650	DRAG NUBS
11	1	B662	B662	SPECIAL AGENT SLIDER

— Continued on next page —

7.1 ICE-CONTROL NOZZLE VALVED MODELS - cont.

REF #	QTY	MODEL NUMBER		
		(a) BGH-HT50 (b) BH-HT50 (c) BGH-HT50-DS (d) BGH-HT50-PD (e) BGH-HT75-PD (k) BH-HT50 (n) BH-HT75	(f) BGH-HT100-PD (g) BH-HT100-PD (h) BGH-HT120-PD (i) BGH-HT150-PD (j) BH-HT150-PD (l) BH-HT120-PD (m) BH-HT120	(o) BGH-HT1502PD (p) BGH-HT1503PD
				DESCRIPTION
12(d,e,f,g,h,i,l,o)	1	B668	B668	1.0" TAPER PIPE COUPLING
12(a,b,n)	1	B694N	—	1.5" NH ROCKER LUG
12(k,m)	1	B694I	—	1.5" NPSH ROCKER LUG
12(c)	1	B680DS	—	CODE DS COUPLING 1 5/16-12
14	1	B727	B727	NAME LABEL - ICE CONTROL
16	1	B740	B740	BARREL LABEL
17	1	B750	B750	VALVE LABEL
18	1	B770	B770	PORT PLUG
19	1	B785	B785	FLUSH WAVE SPRING
20	1	B540	B540	BARRELL
	1	B570 (e,n)	B570 (f,g,h,i,l,o,p)	SHAFT
	1	B574 (a,b,c,d,k)	—	ANTI-ICING SHAFT
	1	B584	B584	HIGH TEMP SPRING CAN
	1	B760 (a,b,c,d,k)	B760 (f,g,h,i,l)	CONTROL SPRING 100 PSI
	1	B765 (e,n)	—	FORESTRY SPRING 75 PSI
	1	—	B766 (i,j)	CONTROL SPRING 150 PSI
	1	—	B767 (o,p)	CONTROL SPRING 1502
	1	—	B572 (h,i,j,l,m,o,p)	150 PSI SPRING SPACER
21	1	B910	B910	VALVE ASSEMBLY
22	28	V2120	V2120	3/16" DIA. STAINLESS BALL
23	2	V2120-TORLON	V2120-TORLON	3/16" DIA. TORLON BALL
24	4	V2130-TORLON	V2130-TORLON	7/32" DIA. TORLON BALL
25	46	VB119NY	V2135	101 NYLON BALL
26	1	V3040	V3040	1.0" COUPLING GASKET
27	1	V3130	V3130	1.5" COUPLING GASKET
28	1	V4270	V4270	WS-128-F-S02 SMALLEY RING
29	2	V4280	V4280	WSM-50-S02 SMALLEY RING
30	2	VM4195	VM4195	SPRING #C0180-032-0310-S
31	1	VO-030	VO-030	O-RING-030
32	1	VO-127	VO-127	O-RING-127
33	1	VO-128	VO-128	O-RING-128
34	1	VOQ-4124	VOQ-4124	QUADX-4124
35	1	VOQ-4216	VOQ-4216	QUADX-4216
36	1	VOQ-4225	VOQ-4225	QUADX-4225
37	2	VT10Y32SS187	VT10Y32SS187	#10-32 x 3/16" SOCKET SET SCREW
38	2	VT31E18BH500	VT31E18BH500	5/16-18 x 1/2" BUTTON HEAD
40	1	VT37-24SS750	VT37-24SS750	3/8-24 x 3/4" SOCKET SET SCREW
42	1	VT37-16SS312	VT37-16SS312	3/8-16 X 5/16 SOCKET SET
43	1	HM693-U	HM693-U	GRIP SPACER - ULTIMATIC
44	1	HM692-BLK	HM692-BLK	PISTOL GRIP - BLACK
	1	HM994-KIT	HM994-KIT	GRIP COLOR CODED SUBASSEMBLY - 1 EACH RED W/YELLOW & GREEN W/YELLOW STRIPE
45	1	VT37-16SH1.0	VT37-16SH1.0	3/8-16 X 1.00 SHCS

7.2 ICE-CONTROL NOZZLE ELECTRIC REMOTE MODEL

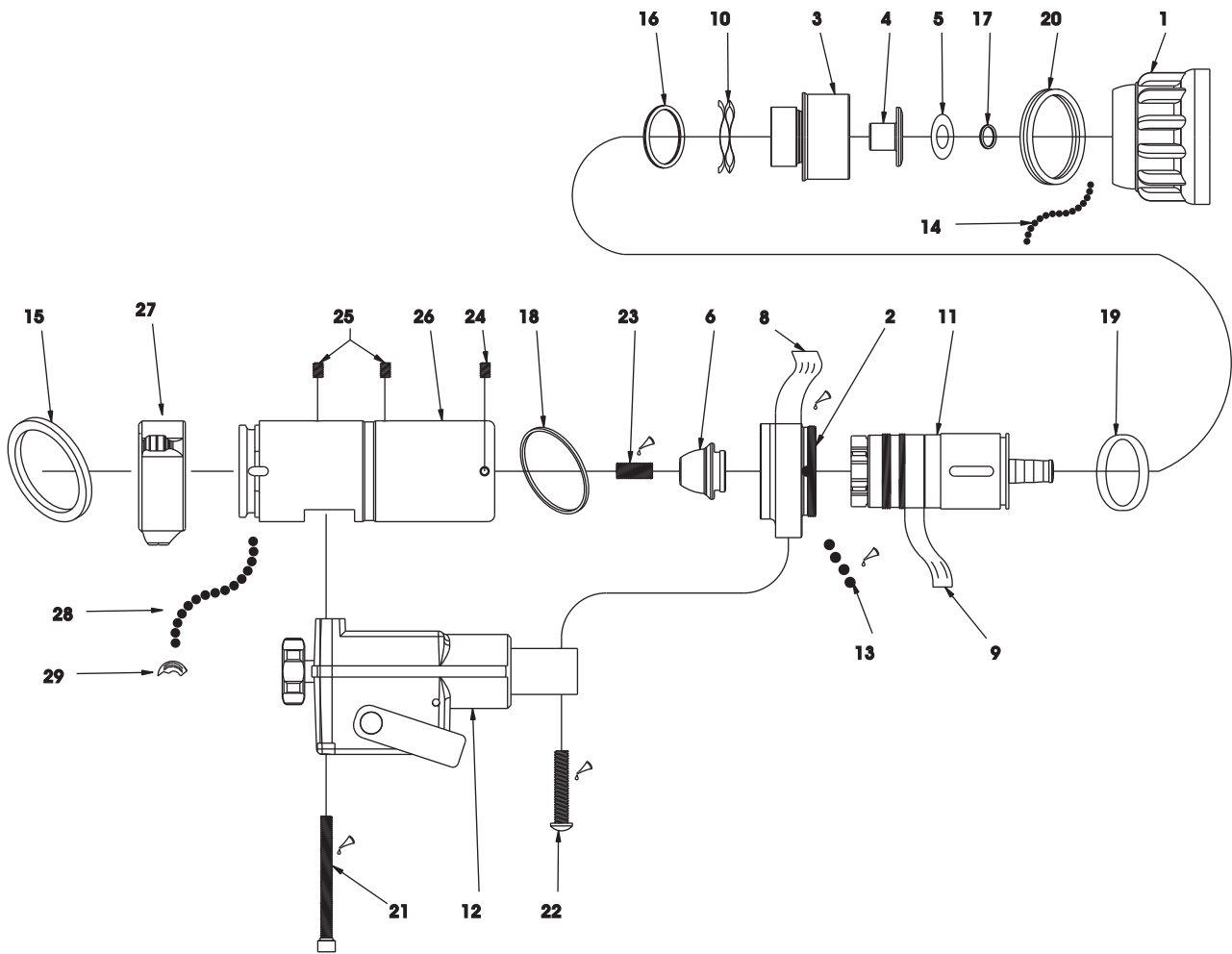

REF #	QTY	MODEL NUMBER		DESCRIPTION
		Part # For 12-24 VDC (a) BER-HT75 (b) BER-HT120 (c) BER-HT150 (d) BER-HT1501 (i) BER-HT1502 (j) BERP-HT150	Part # For 24-36 VDC (e) BER-HT75-HV (f) BER-HT120-HV (g) BER-HT150-HV (h) BER-HT1501HV	
1	1	B504	B504	BUMPER / NO TEETH
2	1	B514	B514	ER SHAPER GUIDE
3	1	B524	B524	BARREL CONE
4	1	B560	B560	BAFFLE
5	1	B567 (a)	B567 (e)	75 PSI SPRING WASHER
	1	B563 (b)	B563 (f)	120 PSI SPRING WASHER
	1	B566 (c, i)	B566 (g)	150 PSI SPRING WASHER
	1	B562 (d)	B562 (h)	SPRING WASHER SPECIAL
	1	—	B561 (i)	SPRING WASHER 20 GPM @ 50 PSI SPRING WASHER 40 GPM @ 150 PSI
6	1	B597	B597	HIGH TEMP NOSE CONE
8	1	B727	B727	ICE-CONTROL NAME LABEL
9	1	B740	B740	BARREL LABEL

— Continued on next page —

7.2 ICE-CONTROL NOZZLE ELECTRIC REMOTE MODEL - cont.

REF #	QTY	MODEL NUMBER		DESCRIPTION
		Part # For 12-24 VDC (a) BER-HT75 (b) BER-HT120 (c) BER-HT150 (d) BER-HT1501 (i) BER-HT1502 (j) BERP-HT150	Part # For 24-36 VDC (e) BER-HT75-HV (f) BER-HT120-HV (g) BER-HT150-HV (h) BER-HT1501HV	
10	1	B785	B785	FLUSH WAVE SPRING
11	1	B544	B544	LINEAR BARREL
	1	B570	B570	SHAFT
	1	B584	B584	HI-TEMP SPRING CAN
	1	B572 (b,c,d, j)	B572 (f,g,h,i)	SPRING SPACER - 150 PSI
	1	B763 (b)	B763 (f)	SPRING 80 PGM @ 120 PSI
	1	B765 (a)	B765 (e)	FORESTRY SPRING 75 PSI
	1	B766 (c,d)	B766 (g,h)	CONTROL SPRING 150 PSI
	1	—	B767 (i)	CONTROL SPRING 1502
12	1	VO-115	VO-115	O-RING-115
	1	B935 (a,b,c,d,i)	—	12 VDC CAST ACTUATOR ASSEMBLY
	1	—	B936	24 VDC CAST ACTUATOR ASSEMBLY
1	B945-ICE (j)	—	12 VDC CAST ACTUATOR ASSEMBLY W/PLUG	
13	4	V2130-TORLON	V2130-TORLON	7/32 TORLON BALL
14	46	VB119NY	V2135	101 NYLON BALL
15	1	V3130	V3130	COUPLING GASKET 1.5"
16	1	V4270	V4270	WS-128-F-S02 SMALLEY RING
17	1	V4280	V4280	WSM-50-S02 SMALLEY RING
18	1	VO-030	VO-030	O-RING-030
19	1	VO-128	VO-128	O-RING-128
20	1	VOQ-4225	VOQ-4225	QUAD RING-225
21	2	VT25-20SH3.0	VT25-20SH3.0	1/4-20 x 3 SOCKET HEAD CAP
22	1	VT31-18BH1.4	VT31-18BH1.4	5/16-18 x 1-7/16 BHCS
23	1	VT37-24SS750	VT37-24SS750	3/8-24 x 3/4 SOCKET SET
24	2	VT10Y32SS250	VT10Y32SS250	10-32 x ¼ SET SCREW ND PATCH
25	2	VT25-20SS375	VT25-20SS375	1/4-20 x 3/8 SOCKET SET
26	1	B663	B663	BASE ER SWIVEL
27	1	F10097N	F10097N	1.5" NH ROCKER LUG
28	34	V2120	V2120	3/16" DIA. STAINLESS BALL
29	1	B770	B770	PORT PLUG

7.3 12-24V ACTUATOR ASSEMBLY WITH PLUG

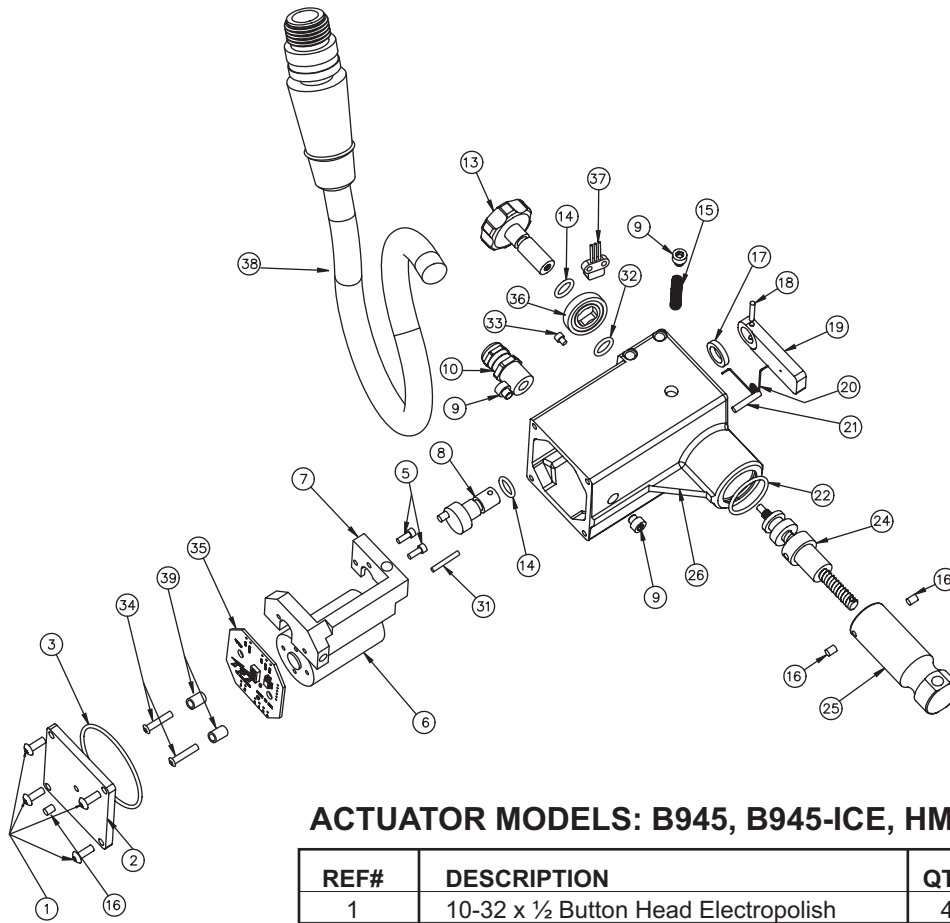

ACTUATOR MODELS: B945, B945-ICE, HM945, M945, MD945, MS945

REF#	DESCRIPTION	QTY	PART #
1	10-32 x 1/2 Button Head Electropolish	4	VT10E32BH500
2	Actuator Cover 12-24 VDC	1	M051-S
3	O-Ring-146	1	VO-146
5	#6-32 x 3/8 Socket Head	2	VT06-32SH375
6	24 VDC Motor 30:1/36 VDC Motor 30:1	1	M044
7	ER Motor Mount	1	M058
8	Cam Machined	1	M049
9	3/8-24 x 3/8 Dog Point	3	H515
10	Strain Relief PG9 .31Hole	1	Y5245
13	Knob - Hardcoat	1	M052
14	O-Ring-109	2	VO-109
15	ER Actuator Spring	1	VM4196
16	10-32 x 1/4 SS ND Patch	3	VT10Y32SS250
17	Washer	1	M053
18	1/8 x 3/4 HDP Spirol Pin	1	VP125X750H
19	Cam Lever - Hardcoat	1	M054
20	Lever Spring	1	M055
21	5/32 x 7/8 HDP Spirol Pin	1	V1900
22	O-Ring-122	1	VO-122
24	Screw Assembly	1	B041, H041, M041, MS041
25	Actuator Tube	1	B104, H104, M104, MS105
26	Actuator Housing - Laser	1	M050
31	Dowel Pin 0.0627	1	UP063X1.00
32	O-Ring-011	1	VO-011
33	4-40 X 1/4 Socket Head Cap Screw	1	VT04-40SH250
34	8-32 X 5/8 Button Head Cap Screw	2	VT08-32BH625
35	Board - Nozzle Actuator Id	1	Y5460
36	Magnet - 1" OD 30 Pole	1	Y5465
37	Sensor - Hall Effect 3 Wire 4.5-24 Volts	1	Y5470
38	Cable - 6 Pole Male In-Line Plug	1	Y5480
39	Spacer - Round Aluminum Thru-Hole	2	Y5537

7.4 24-36V ACTUATOR ASSEMBLY

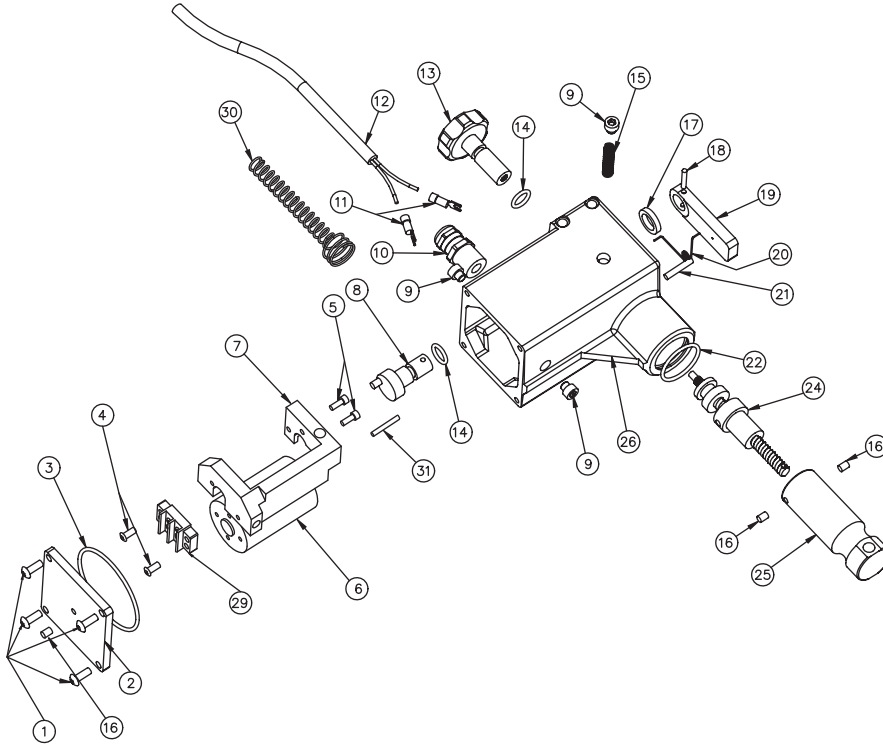

ACTUATOR MODELS: B936, M936, MS936

REF#	DESCRIPTION	QTY	PART #
1	10-32 x 1/2 Button Head Electropolish	4	VT10E32BH500
2	Actuator Cover 24-36 VDC	1	M051-S
3	O-Ring-146	1	VO-146
4	8-32 x .375 Button Head Electropolish	2	VT08E32BH375
5	#6-32 x 3/8 Socket Head	2	VT06-32SH375
6	36VDC Motor 30:1 Worm	1	H046
7	ER Motor Mount	1	M058
8	Cam Machined	1	M049
9	3/8-24 x 3/8 Dog Point	3	H515
10	Strain Relief PG9 .31Hole	1	Y5245
11	#6 Sealed Spade Term. 18-22 GA.	4	V4103
12	18/2 SJOOW 600 Volt Black	6	V4075
13	Knob - Hardcoat	1	M052
14	O-Ring-109	2	VO-109
15	ER Actuator Spring	1	VM4196
16	10-32 x 1/4 SS ND Patch	3	VT10Y32SS250
17	Washer	1	M053
18	1/8 x 3/4 HDP Spirol Pin	1	VP125X750H
19	Cam Lever - Hardcoat	1	M054
20	Lever Spring	1	M055
21	5/32 x 7/8 HDP Spirol Pin	1	V1900
22	O-Ring-122	1	VO-122
24	Screw Assembly	1	B041, M041, MS041
25	Actuator Tube	1	B104, M104, MS105
26	Actuator Housing - Laser	1	M050
29	Terminal Block - 2 Pos. 20 A 150 V #6 SCR	1	V4145
30	Cord Protector	1	VM4093
31	Dowel Pin 0.0627	1	VP063X1.00

8.0 ANSWERS TO YOUR QUESTIONS

We appreciate the opportunity of serving you and making your job easier. If you have any problems or questions, our toll-free "Hydraulics Hotline", 800-348-2686, is normally available to you 24 hours a day, 7 days a week.

9.0 INSPECTION CHECKLIST

Nozzle must be inspected periodically for proper operation and function according to this checklist periodically.

On models with a hand operated valve, check that:

- 1) There is no obvious damage such as missing, broken or loose parts, damaged labels, etc.
- 2) Coupling is tight and leak free.
- 3) Valve operates freely through full range of settings.
- 4) "OFF" position does fully shut off and flow stops.
- 5) Nozzle flow is adequate as indicated by pump pressure and nozzle reaction.
- 6) Shaper turns freely and adjusts pattern through full range.
- 7) Shaper turns into full flush and out of full flush with normal flow and pressure restored.

On models with an electric remote control, check that:

- 1) There is no obvious damage such as missing, broken or loose parts, damaged labels, frayed or cracked wiring, etc.
- 2) Coupling is tight and leak free.
- 3) Nozzle flow is adequate as indicated by pump pressure and nozzle reach.
- 4) Shaper moves freely and adjusts pattern through full range by electric and manual control.
- 5) Shaper moves into full flush and out of full flush with normal flow and pressure restored by electric and manual control.
- 6) Electric remote actuator mountings are tight.
- 7) Manual override controls operate freely and through full range of motion.



Any ice-control nozzle failing any part of the inspection checklist is unsafe. Correct this problem before use. Operating a nozzle that fails any of the above inspections is a misuse of this equipment.

10.0 WARRANTY

Task Force Tips, Inc., 3701 Innovation Way, Valparaiso, Indiana 46383-9327 USA ("TFT") warrants to the original purchaser of its Ice-Control series nozzles ("equipment"), and to anyone to whom it is transferred, that the equipment shall be free from defects in material and workmanship during the five (5) year period from the date of purchase.

TFT's obligation under this warranty is specifically limited to replacing or repairing the equipment (or its parts) which are shown by TFT's examination to be in a defective condition attributable to TFT. To qualify for this limited warranty, the claimant must return the equipment to TFT, at 3701 Innovation Way, Valparaiso, Indiana 46383-9327 USA, within a reasonable time after discovery of the defect. TFT will examine the equipment. If TFT determines that there is a defect attributable to it, TFT will correct the problem within a reasonable time. If the equipment is covered by this limited warranty, TFT will assume the expenses of the repair.

If any defect attributable to TFT under this limited warranty cannot be reasonably cured by repair or replacement, TFT may elect to refund the purchase price of the equipment, less reasonable depreciation, in complete discharge of its obligations under this limited warranty. If TFT makes this election, claimant shall return the equipment to TFT free and clear of any liens and encumbrances.

This is a limited warranty. The original purchaser of the equipment, any person to whom it is transferred and any person who is an intended or unintended beneficiary of the equipment, shall not be entitled to recover from TFT any consequential or incidental damages for injury to person and/or property resulting from any defective equipment manufactured or assembled by TFT. It is agreed and understood that the price stated for the equipment is in part consideration for limiting TFT's liability. Some states do not allow the exclusion or limitation of incidental or consequential damages, so the above may not apply to you.

TFT shall have no obligation under this limited warranty if the equipment is, or has been, misused or neglected (including failure to provide reasonable maintenance) or if there have been accidents to the equipment or if it has been repaired or altered by someone else.

THIS IS A LIMITED EXPRESS WARRANTY ONLY. TFT EXPRESSLY DISCLAIMS WITH RESPECT TO THE EQUIPMENT ALL IMPLIED WARRANTIES OF MERCHANTABILITY AND ALL IMPLIED WARRANTIES OF FITNESS FOR A PARTICULAR PURPOSE. THERE IS NO WARRANTY OF ANY NATURE MADE BY TFT BEYOND THAT STATED IN THIS DOCUMENT.

This limited warranty gives you specific legal rights, and you may also have other rights which vary from state to state.

Made in USA
<http://deicing.tft.com>

TASK FORCE TIPS, Inc.
Made in USA - <http://deicing.tft.com>

3701 Innovation Way • Valparaiso , IN 46383-9327 USA
800.348.2686 • 219.462.6161 • Fax 219.464.7155